



VICTORIAN, BUCKINGHAM & BUCKINGHAM ECO DETAILED INSTALLATION INSTRUCTIONS Rev 3 Nov 2013

Door elevations are shown from the **OUTSIDE VIEW**.



XO DOOR

'X' denotes the active or moving panel(s).

'O' denotes the inactive or fixed panel(s).



OX DOOR

All 2 panel doors between 72" to 84" high are fully reversible. The locking hardware on the operating panel is located at the mid-point of the panel unless otherwise requested. For 3 and 4 panel doors, refer to the supplemental instruction sheet. All other doors are handed and are not reversible.

NOTE: If you have purchased a pre-assembled door, we recommend removing the panels before moving the door around the construction site. Rough handling may damage joint assemblies which could result in reduced product performance.

ROUGH OPENING

The rough opening should be made 1/2" wider and 1/2" higher (+/-1/8" each way) than the actual door frame size. (Refer to catalogue for standard frame sizes.) The sill or base of the opening must be solid, level, and of sufficient width and depth to support the entire door sill in a continuous and uniform manner. It is important that the opening be plumb and square as the door will not perform to its potential if installed into an improperly prepared opening.

MAIN FRAME ASSEMBLY (for Knocked Down (KD) doors)

If you have purchased an assembled door, go to "Frame Installation" step.

The frame consists of 4 main members:

Head, Sill, Right Jamb, Left Jamb.

All main frame members are machined so that they may be assembled in only one way. Lay out the framing members as shown on Diagram A.

Ensure that the foam gaskets attached at the top and bottom of the jambs are in good condition and replace if they appear torn or defective.

For Victorian and Buckingham, use the #8 X 2-1/2" screws provided to fasten the head and sill to the jambs through the factory drilled holes making sure the screws are drawn tight. For Buckingham Eco, the frame screws are #10 x 3".

If exterior brick mold, nailing fin, sill extensions, or interior jamb and sill extensions are being used, refer to the supplemental instruction sheet before proceeding with the frame installation.

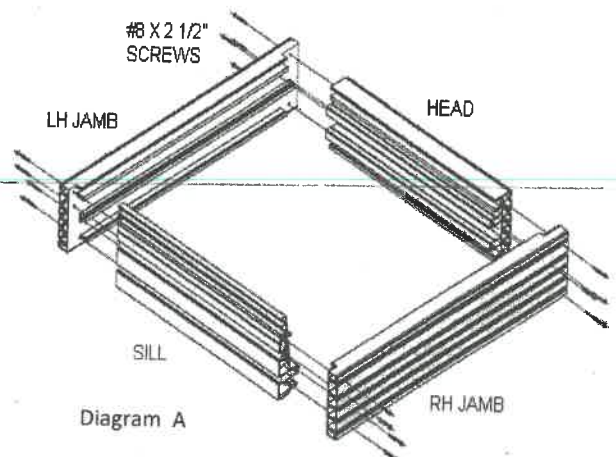

FRAME INSTALLATION

The main frame is always installed with the sill sloping to the outside. Due to varying site conditions, installation materials are not supplied with the door.

Diagram B shows the recommended configuration to install the sill.

The sill must be installed level and uniformly supported from end to end and from front to back. Use a level, and use solid shims if necessary to compensate for unevenness in the opening.

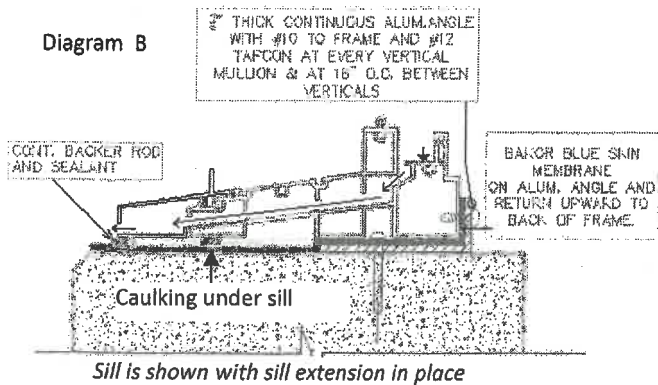

It is highly recommended that screws are not driven vertically down through the sill to prevent possible leaks. The optimal method is to install an angle or sill plate on the subfloor. Apply Blue Skin along the sill plate to the outside of the sill. If the sill extends beyond angle or sill plate, install shims to level the sill. Apply a heavy bead of good quality urethane caulking along the full width of the sill opening inset $\frac{1}{2}$ " from the line the sill will be installed to, excluding sill extension if provided, so that front of the sill will embed into the sealant. (See Diagram B) Insert the main frame into the opening and centre the door frame leaving equal clearance at both jambs.

In the event that the project specifications require the use of vertical screws to fasten down the sill, it is the responsibility of the installer to pre-drill pilot holes for these screws. The pilot holes should avoid penetrating the drainage channels inside the sill (see arrows in Diagram B). Cap plugs are recommended for aesthetic reasons to fill the pilot holes and to conceal the installation screws.

The header must be anchored at each meeting or parting rail, but this will be accomplished **AFTER** panel installation during the application of the anti-lift block.

The jambs must be fastened within 6" of each corner and at mid height on doors up to 80" high. Additional fastening is required on taller doors. At this time, only the top and bottom screws on the operating side jamb are to be installed. Other installation screws will be installed during hardware fastening.

Set shims behind frame installation holes to make the main frame plumb and square then temporarily fasten the frame to the surrounding structure. Using a level and measuring diagonally, check that the frame is straight, plumb and square, make adjustments to the shims if necessary, and securely fasten all screws, with the exception the mid span screw on the operating panel side. Buckingham Eco doors may require extra attention with shims at center of jambs and head.

NOTE: For installations in high rise buildings or high wind areas, the quantity, size, type, and engagement of the fasteners and the supporting shims must be engineered and is the responsibility of the installation contractor.

INSTALLING THE FIXED PANEL ADAPTOR AND END CAP

The fixed panel adaptor is shipped attached to the sill and must be positioned to the fixed panel side by sliding it tight to the fixed jamb following fastening of the frame to the structure. To hold the fixed panel adaptor in place, insert and attach the "End Cap" against the open end of the fixed panel adaptor as shown on Diagram C. Ensure that the hole and screw securing the "Fixed Panel End Cap" to the sill is caulked and water tight.

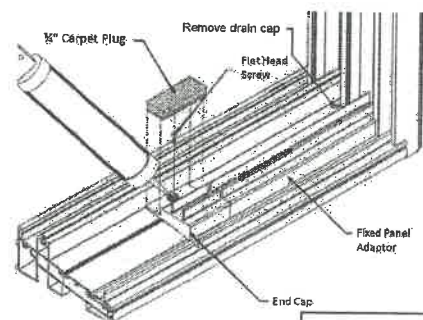
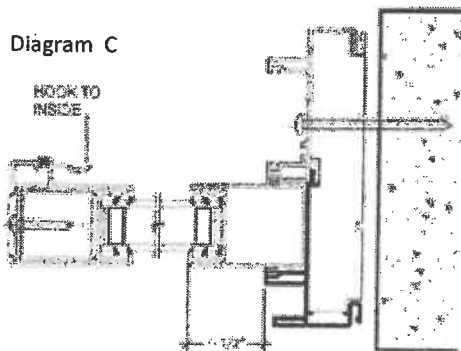

Diagram C

Install the $\frac{3}{4}$ " wide carpet plug on top of the end cap covering the screw. Remove the $\frac{3}{8}$ " cap from drain on fixed panel side. On moving panel side, leave the drain capped.

INSTALLING THE FIXED PANEL



The fixed panel is supplied with screw covers at the top and bottom of the meeting rail. The plain cut cover is to be located at the bottom of the panel and the notched cover is to be located at the top. Remove and reverse to suit your door handing if necessary. Slide the screw covers away from the top and bottom of the meeting rail before installing the panel into the frame.

Lift the fixed panel into the centre track of the frame head and carefully lower onto the fixed panel adaptor on the sill. Push the fixed panel securely and completely into the jamb as shown on Diagram D. The meeting rail with interlocking hook and the wool pile weather stripping should now be in

the middle of the door facing inside.

Fasten the fixed panel to the jamb by installing five #8 X 1" screws through weather-stripping channel into the jamb leg as shown in Diagram E. Install jamb pocket cover to close off the interior jamb pocket and hide the screws.

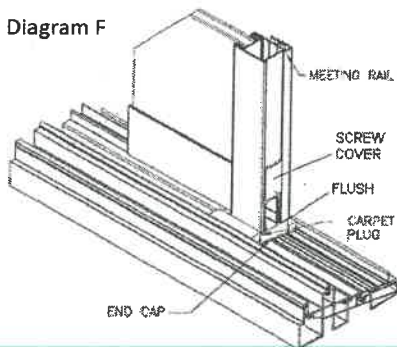
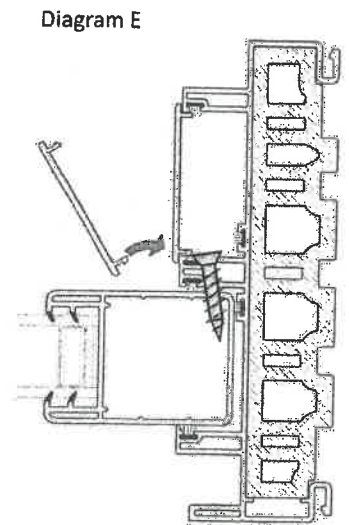

Tap the screw covers at the top and bottom of the free end of the fixed panel up and down against the head and sill. The plain cut cover at the sill should finish on top of the Fixed Panel End Cap as shown on Diagram F. If it slides downwards beyond the end cap, this indicates that the fixed panel is not fully engaged into the jamb. Re-install the fixed panel if necessary.

INSTALLING THE OPERATING PANEL

Firstly, depending on the handing or the door, install the rollers into the bottom of the operating panel into the pre-drilled holes provided using the #8 X $\frac{1}{2}$ " screws provided. Ensure that the adjustment screw head on the roller assembly is facing outwards towards the end of the panel.

The operating panel is supplied with screw covers at the top and bottom of the meeting rail. The cover with the rounded notch is to be located at the bottom of the panel and the square notch is to be located at the top. Remove and reverse to suit your door handing if

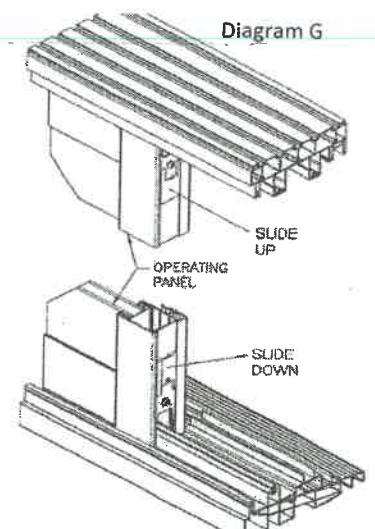

necessary. Slide the screw covers away from the top and bottom of the meeting rail before installing the panel into the frame.

Lift the active panel into the inside track of the frame head and carefully lower the panel onto the roller track of the sill frame as shown on Diagram G.

Using a hand held screw driver, adjust the rollers up or down so that the exterior bottom of the panel is riding $\frac{1}{2}$ " above the sill. See Diagram H. Turn the screw clockwise to raise the panel or counter clockwise to lower the panel as shown on Diagram H. NOTE: We recommend lifting the panel slightly when adjusting the wheels for ease of turning and to prevent thread stripping the adjustment mechanism.

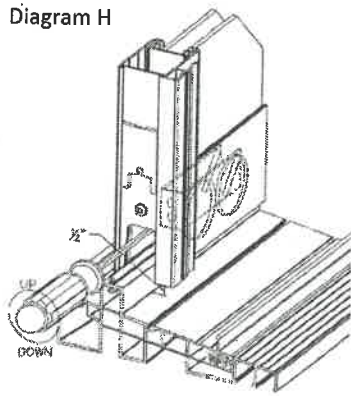

Slide the panel in the closing direction to within $\frac{1}{4}$ " of the jamb. The gap between the panel and the jamb should be uniform from top to bottom. If not, adjust the panel up or down at one corner until the panel aligns to the jamb. If the jamb is bowed, remove the installation screws, adjust the shims, and re-fasten.

Once the panel wheels have been adjusted, tap the screw covers at the top and bottom on the side of the meeting rail up and down towards the head and sill.

HARDWARE AND KEEPER INSTALLATION

For KD doors, the handle and lock set is packaged separately with its own instructions. Refer to these instructions to install the handle and lock.

The standard handle for Victorian, Buckingham and Buckingham Eco doors is the Elite handle shown in Diagram I. Install the lock mechanism into the pre-drilled slot in the side of the operating panel with the adjustment screw to the top and the striker hook facing upwards. Insert the thumb lever into the slot on the inside of the lock mechanism as shown on Diagram I.

Install the interior and exterior pull handles with the screws provided from the inside. Ensure the exterior pull is installed as shown on Diagram I.

To locate the latch keeper on the jamb, open the operating panel, nest the keeper into the opening on the lock mechanism, and engage the thumb turn to hold the keeper within the lock mechanism. Apply a piece of 2 sided tape to the back of the keeper and firmly close the panel into the jamb. Disengage the thumb turn and slide away the operating panel. The latch keeper should be held in the jamb by the 2 sided tape. Mark the keeper

location with a pencil and remove the tape.

Install solid shims between the jamb and the opening and attach the keeper to the jamb and into the surrounding structure with two $2 \frac{1}{2}$ " screws as shown on Diagram J.

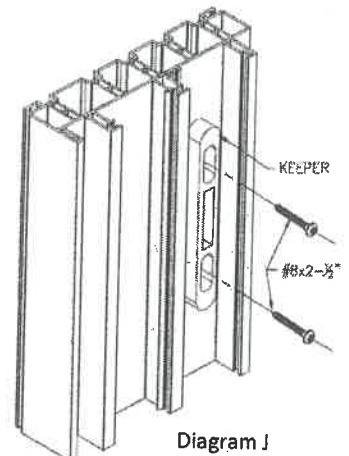

NOTE: Install the screws through the centre of the slots in the keeper to allow for future vertical adjustments if necessary.

ANTI LIFT BLOCK/ MEETING RAIL HEAD PLUG INSTALLATION

After all panels are installed in the frame and with the operating panel in the open position, insert the anti-lift block with the "carpet plug" facing down into the head between the two tracks and slide it horizontally until it is above the fixed panel meeting rail.

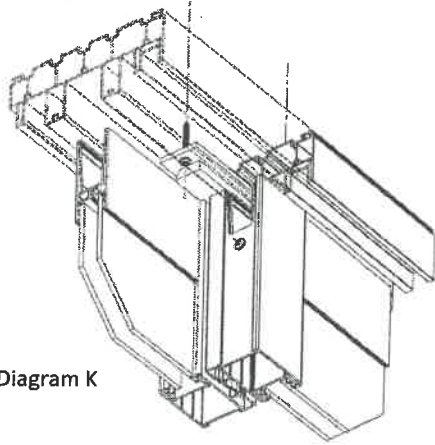

Diagram K

Insert shims between the head and the surrounding structure above the meeting rail ensuring that the head frame is true and not bowed.

Using #8 X 2 1/2" screws provided fasten the block through the hole provided, through the head frame, the shims, and into the surrounding structure. Close the operating panel and fasten the other end of the block in the same manner from the inside. See Diagram K.

If installed correctly, it should not be possible to lift the panels out of the door, and the "carpet plug" will close the space between the fixed and operating panels.

SCREEN INSTALLATION

Insert the screen in the outside track of the frame head, swing the bottom of the screen towards the sill, then depress the bottom rollers with a flat head screw driver or spatula and snap the rollers over the sill screen track as shown on Diagram L.

Slide the screen in the closing direction to within 1/4" of the jamb. Visually, the joint between the screen and the jamb should be uniform from top to bottom.

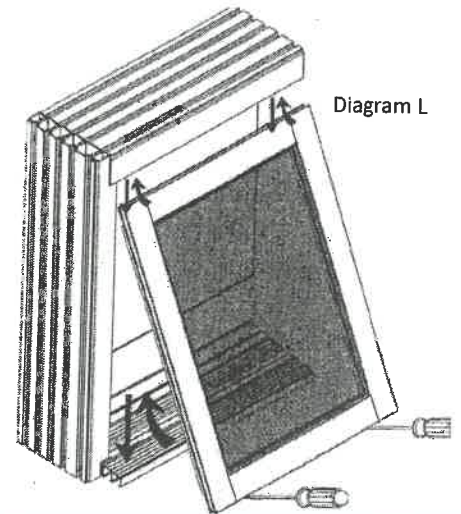

Diagram L

Using a screwdriver adjust the rollers on the bottom of the screen upwards or downwards to align the screen as shown on Diagram M. Adjust the top rollers just enough to snug the screen in the top track and allow easy rolling.

With the striker latch in the open position, slide the screen close to the jamb (or astragal mullion on OXO doors), mark the location of the top of the striker in the jamb, and position the keeper within the jamb so that the striker will cleanly engage the keeper. Attach the keeper to the jamb using the self drilling screws provided. Ensure the latch securely holds the screens locked and adjust the keeper up or down as necessary.

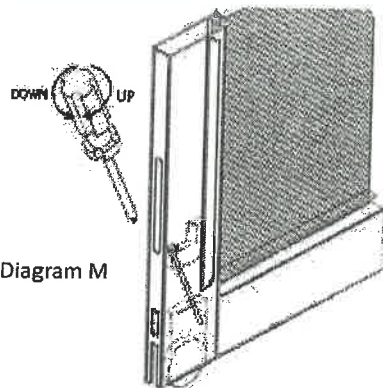

Diagram M

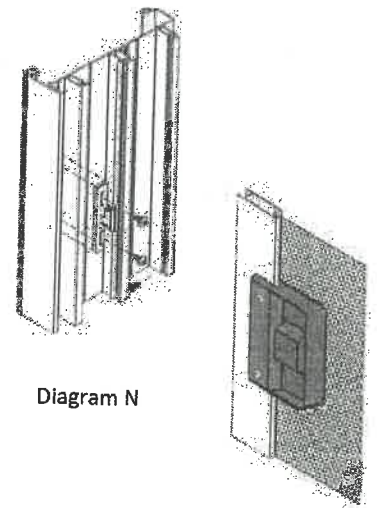

Diagram N

CAULKING

Use a good quality building sealant that is compatible with the vinyl surfaces of the sliding door and the surrounding structure. It is important that all surfaces to be caulked are free of dirt, dust, and other contaminants and are well cleaned with an isopropyl alcohol solution followed by a clean dry wipe. Depending on the sealants being used, a primer may also be necessary. Check the application with your sealant supplier.

The use of backer rod is recommended to prevent the caulking from shrinking into the joint (see Diagram B).

CAUTION: If expanding foam insulation is being used to fill the void between the door frame and surrounding structure, we recommend the use of good quality LOW EXPANDING FOAM material only applied by an experienced applicator. The use of high expanding foam can bow and deform framing members resulting in poor performance and difficult operation of the door.

CLEANING

Remove all debris and vacuum all dirt and filings from the sill. Debris on the sill or in the drainage channels will prevent the door from performing properly. See Diagram B for an indication of the location of the drainage channels.

Using a mild soap and water solution, clean all vinyl and glass surfaces. Do not use solvents or harsh cleaners as they may damage the finish surfaces.

REVERSING

Doors with a center-punched lock rail (i.e. the lock is located equidistant from the top and bottom) can be reversed to open in the opposite direction.

First remove screen and the anti-lift block (see Diagram L and Diagram K). Remove the operating panel and swap the screws covers in the interlocking rail of the operating panel (Diagram G). Remove both lock keepers from the lock jamb. Unclip the pocket cover using a straight edge or screwdriver (see Diagram E). Unscrew and remove the fixed panel. Swap the screw covers on the interlocking rail of the fixed panel. Remove the fixed panel end cap (see Diagram C). Unclip the fixed panel adaptor and install on the opposite side of the sill. Reinstall the fixed panel end cap. Install the fixed panel and screw in place (Diagram E). Install a jamb screw into the support structure of the building on the fixed jamb side (see Diagram D). Clip in the pocket cover (Diagram E). Install the operating panel and keepers. Install the anti-lift block. Install the screen. Adjust the rollers and confirm that the door functions properly. Use screw caps to cover any exposed screw heads or touch up holes with caulking.